

PHOENIXVILLE BOROUGH COUNCIL

Tuesday, February 10, 2026

7:00 PM

AGENDA

- I. Pledge of Allegiance/Moment of Silence
- II. Roll Call – Borough Manager
- III. Public Comment
- IV. Presentations
 - A. Motion to approve the Independent Contractor Agreement between Dr. Kevin J. Duffy and the Borough of Phoenixville with an effective date of December 16, 2025.
 - B. Swearing in of Medical Director Kevin J. Duffy, MD.
 - C. Swearing in of Firefighter Stephen Cini
 - D. Swearing in of Firefighter Colin Finn
 - E. Swearing in of Firefighter Andrew Bucklin
- V. Consent Agenda
 - A. Approval of January 13, 2026 Regular Meeting Minutes and February 9, 2026 Special Meeting Minutes.
 - B. Items from Parks and Recreation Committee:
 - 1. Motion to recommend Borough Council approve a Temporary Community Event Application for First Fridays on Friday, May 1, June 5, July 3, August 7, September 4, October 2, November 6, and December 4, 2026 from 5:30 pm to 8:30 pm on the 100 and 200 Block of Bridge Street and the Bridge and Main Street Parking Lot. Bridge Street to be closed between Gay Street to Main Street and Main Street to Starr Street from 2:00 to 10:00 pm. Main Street to be closed between Church Street and Bridge Street during the First Fridays of June through October from 2:00 to 10:00 pm. The Bridge and Main Street Parking Lot to be closed from 8:00 am to 10:00 pm on each Friday.
 - 2. Motion to recommend Borough Council approve a Temporary Community Event Application for WuFF Jam 2026 on Saturday, September 19, 2026, from 11:00 am to 5:00 pm in Reeves Park. Third Avenue between Main Street and B Street to be closed from 7:00 am to 5:00 pm. Conditioned upon receipt of valid Certificate of Insurance naming Borough as Additional Insured.

C. Items from Finance Committee:

1. Motion to approve the 2025 Pre-Paid dated 11/1/2025 - 11/30/2025 in the amount of \$854,371.52.
2. Motion to approve the 2025 Pre-Paid dated 12/1/2025 - 12/31/2025 in the amount of \$2,342,451.86.
3. Motion to approve the 2025 Pre-Paid Credit Card Statement dated 11/1/2025 - 11/30/2025 in the amount of \$63,752.76.
4. Motion to approve the 2025 Pre-Paid Credit Card Statement dated 12/1/2025 - 12/31/2025 in the amount of \$38,351.51.
5. Motion to approve the 2025 Pre-Paid ACH dated 11/30/2025 in the amount of \$1,719,111.70.
6. Motion to approve the 2025 Pre-Paid ACH dated 12/31/2025 in the amount of \$68,593.93.
7. Motion to approve the Staff recommendation authorizing the Finance Director to make the necessary end of year adjustments and to provide a listing of those adjustments to the Finance Committee and the Borough's Auditor.

VI. Communications/Council Participation

VII. Mayor's Report

VIII. Appointments

- A. Call for Residents interested in being appointed to various Boards and Commissions.
- B. Overview of process when applications are received.

IX. New Business

- A. Motion to approve a Settlement Agreement between the Borough and Steelworks Acquisition, LP related to the Demolition Order issued by the Borough on September 30, 2025 for the properties located at 521, 523, 525, 527, 529, 535, 541, and 543 Bridge Street, and the appeal thereof by the landowner, in a form substantially similar to what has presented to Council tonight, and further authorizing the Borough Council President, Borough Manager, and Borough Solicitor to execute such Settlement Agreement and prepare, file and execute any further documents necessary to comply with the terms and conditions of such Settlement Agreement.

X. Public Hearings

XI. Resolution/Ordinances

- A. Motion to adopt an Ordinance amending Chapter 13 (Licenses, Permits and General Business Regulations).
 - B. Motion to recommend Borough Council adopt a Resolution Establishing Conditions and Regulations for the PXV Inside-Out Special Event, Pursuant to Section 13-1304 of the Borough Ordinances.
- XII. Reports of Committees, Boards, and Commissions
- A. Historical and Architectural Review Board – Ms. Dugan
 - 1. Motion to approve/deny the Certificate of Appropriateness for renovations and additions at 184 Bridge Street.
 - B. Planning Commission - Mr. Moore
 - 1. Motion to adopt a Resolution officially conditionally approving/denying the Preliminary/Final Subdivision and Land Development Plan for the development at 1000 Nutt Road known as the Chipotle Pad Site.
 - C. Phoenixville Regional Planning Committee – Mrs. McGhee
 - D. Recreation Board – Ms. Dugan
 - E. Tree Advisory Commission – Mr. Weiss
 - F. Human Relations Commission – Ms. Burckley
- XIII. Council Action referred from:
- A. Personnel and Public Safety Committee- Ms. Burckley
 - 1. No action to report.
 - B. Parks and Recreation Committee - Mr. Moore
 - 1. No action to report.
 - C. Policy Committee - Mrs. Vogel
 - 1. Motion to schedule and advertise an Ordinance amendment to Chapter 1 “Administration and Government”.
 - 2. Motion to schedule and advertise an Ordinance amendment to Chapter 15 “Motor Vehicles”.
 - 3. Motion to schedule and advertises an Ordinance amendment to Chapter 27 “Zoning”.
 - D. Infrastructure, Technology Transportation & Sustainability Committee - Mr. Weiss

- 1. No action to report.
- E. Finance Committee - Ms. Dugan
 - 1. No action to report.
- XIV. Public Comment
- XV. Communication/Council Participation
 - A. Nominations to fill the vacant North Ward Borough Council Seat.
 - B. Motion to adopt a Resolution to fill the vacant North Ward Borough Council Seat.
- XVI. Staff Reports
 - A. Manager
 - B. Police
 - C. Fire
 - D. Planning and Codes
 - E. Public Works
 - F. Finance
 - G. Human Resources
 - H. Recreation
- XVII. Adjournment

Upcoming Meetings:

Planning Commission	February 12 – 6:00 pm
Parks and Recreation Committee	February 17 – 6:00 pm
Infrastructure Committee	February 17 – Immediately following Parks and Rec
Finance Committee	February 24 – 6:00 pm
Policy Committee	February 24 – Immediately following Finance
Tree Advisory Commission	March 2 – 6:00 pm
HARB	March 2 – 5:00 pm
Personnel/Public Safety Committee	March 3 – 6:00 pm
Civil Service Commission	March 3 – 7:00 pm
Human Relations Commission	March 4 – 5:00 pm
Borough Council	March 10 – 7:00 pm
Recreation Board	April 20 – 6:30 pm

Employee Service Anniversaries – February

Melissa Gibbons, Parks & Recreation Director – 24 years

Jim Ross, Water Treatment MRO – 22 years
Lt. Bryan MacIntyre, Police Department – 19 years
Don Kline, Assistant Water Treatment Superintendent – 9 years
Joe Frosch, Lead Parking Officer – 8 years
Tom Madden, Codes Permit Coordinator – 7 years
Ofc. Jeremy Fonseca, Police Department – 7 years
Pat McCann, Customer Service Representative – 5 years
Alexis Showers, Accounts Payable Clerk – 5 years
Jack Nudy, Firefighter – 1 year
Carl Cullen, Parking Officer – 1 year
Tanner Kouba, Firefighter – 1 year

PHOENIXVILLE BOROUGH COUNCIL
Tuesday, January 13, 2026
7:00 PM

MINUTES

I. Pledge of Allegiance/Moment of Silence

II. Roll Call – Borough Manager

Mr. Ewald, President	Present
Ms. Burckley, Vice President	Present
Ms. Dugan	Present
Mrs. McGhee	Present
Mr. Moore	Present
Mr. Strenfel	Absent
Mrs. Vogel	Present
Mr. Weiss	Present
Mayor Urscheler	Present
Mr. Krack, Borough Manager	Present
Ms. Getzfread, Asst. Borough Manager	Present
Chief Marshall, Police Chief	Present
Mr. Denlinger, Solicitor	Present

III. Public Comment

Colleen Lucchesi, resident. She expressed her concerns with her multiple attempts through Right to Know to access the records regarding the passing of her ex-husband. She explained that it has been over a year and that the case is inactive and she would like a copy of the police report and the return of Mr. Lucchesi’s cell phone. She also stated she feels she is paying too much for her trash service.

IV. Presentations - None

V. Consent Agenda:

A. Approval of December 9, 2025, Regular Meeting Minutes and the January 5, 2026, Reorganization Meeting Minutes.

B. Items from HARB

1. Motion to approve the Certificate of Appropriateness for signage at 18 Gay Street.
2. Motion to approve the Certificate of Appropriateness for signage at 26 Main Street.

Ms. Burckley made a Motion to approve the Consent Agenda. Seconded by Mr. Weiss.

Motion Approved 7-0.

VI. Communications/Council Participation

Ms. Burckley stated she had the pleasure of attending the last call for Officer Vincent Stabillo after 27 years of service to the Phoenixville Police Department.

VII. Mayor's Report

Mayor Urscheler congratulated the newest Council members who are here with us tonight, and he thanked all of the former Council members and members who have resigned from our boards and commissions for their extraordinary service to the Borough. He reported that on January 9th the Phoenixville Community Health Education Foundation hosted the Harlem Wizards at the middle school. It was a great event. Over 900 people in our school district went and turned out to help support the Community Education Foundation. On the 17th is an MLK event at 2 p.m. at Bethel Baptist Church. He encouraged everyone to check out their website and their Facebook to learn more about that. On the 27th of January will be the State of the 6th. You can visit our Congresswoman Chrissy Houlihan's website to find out more information about the State of the 6th that will be hosted here in the Borough.

Mr. Ewald reported that prior to tonight's agenda the Council held an executive session to discuss a matter of attorney-client privilege related to the 500 block of Bridge Street and a matter of litigation with Michael Marcavage.

VIII. Appointments

- A. Call for Residents interested in being appointed to various Boards and Commissions.

Mr. Ewald encouraged residents to continue to apply for openings on the various Boards and Commissions and stated openings can be found on the Borough's Website.

- B. Motion to reappoint Beth Burckley to the Civil Service Commission with a new term ending January 31, 2032.

Mr. Weiss made a Motion to reappoint Beth Burckley to the Civil Service Commission with a new term ending January 31, 2032. Seconded by Mr. Moore.

On the Question:

Ms. Dugan asked for clarification as she believed the appointment of Ms.

Burckley was a temporary appointment and she stated she would support this as a permanent appointment.

Mr. Ewald stated that it did initially start as one year appointment as there was a turnover issue and the commission was failing to meet the requirement of a quorum.

Mr. Krack explained that there was a void on the commission as it had no alternates and was down to two members and the requirement is three members for a quorum. He stated it is the one part of the Borough Code that does allow the Council to appoint a Councilperson, which was done in 2023 and that term runs out at the end of January.

Ms. Dugan asked if it would be more appropriate to have the Council President make this appointment.

Mr. Krack explained it has to be an appointment of the Council.

Ms. Dugan acknowledged this appointment is similar to other boards and commissions of Council. And, she believes it should be a regular appointment to have a Councilperson on Civil Service.

Mr. Krack stated that is certainly up to the Council and with tonight's appointment being passed it will not have to be considered again until 2032.

Motion approved 7-0.

- C. Motion to adopt a Resolution reappointing Bryan Emmanuel to the Zoning Hearing Board for a new term ending January 31, 2031.

Ms. Burckley made a Motion to adopt a Resolution reappointing Bryan Emmanuel to the Zoning Hearing Board for a new term ending January 31, 2031. Seconded by Mr. Weiss.

Motion Approved 7-0.

IX. New Business

- A. Motion to accept the resignation of North Ward Councilman David Strenfel effective January 13, 2026.

Ms. Burckley made a Motion to accept the resignation of North Ward Councilman David Strenfel effective January 13, 2026. Seconded by Mrs. McGhee.

Motion Approved 7-0.

- B. Review ZHB Application from the owner of 317 Second Avenue seeking a variance from Zoning Ordinance § 27-405 to construct a parking spot and to determine whether to take no action, send the Borough Solicitor to the February 18, 2026, Zoning Hearing Board Meeting, or send written statement to the Zoning Hearing Board.

Mr. Denlinger explained the Borough received a Zoning Hearing Board application for 317 2nd Avenue. This application is seeking a variance to construct an on-lot parking spot in the front yard. Section § 27-405 of the zoning ordinance does not permit parking spaces in the front yards of properties. The property at 317 is a little unique because it's a corner property, so it technically has two front yards. He stated the Council is not required to take any action on this item, but we bring it to Council's attention in case they would like to take action. If the Council takes no action, then the Zoning Hearing Board will hear this application in its normal course and absent of concerns from Council that he hasn't considered, his expectation would be no action.

Mr. Moore stated at the Planning Commission the request was reviewed, a map of the area was viewed, and he feels this request would not be creating a precedent. The location of the proposed parking space is facing Quick Street, it appears there was an illegal parking spot there previously and there is no back alley that would allow for additional parking. For these reasons the Planning Commission felt there was no need to take action on the application.

No Action taken.

- C. Motion to accept Staff's recommendation to award the 2026 Tree Removal Services Contract to Sky High Services, LLC for a total contract value of \$95,850 as the lowest responsible bidder.

Mr. Weiss made a Motion to accept Staff's recommendation to award the 2026 Tree Removal Services Contract to Sky High Services, LLC for a total contract value of \$95,850 as the lowest responsible bidder. Seconded by Ms. Dugan.

On the Question:

Ms. Burckley stated she is not familiar with this vendor, but she trusts the Staff has done the appropriate vetting and she is comfortable with the recommendation.

Motion Approved 7-0.

X. Public Hearings - None

XI. Resolutions/Ordinances

- A. Motion to adopt a Resolution acknowledging Koretta McGhee for her service on the Human Relations Commission.

Ms. Bureckley made a Motion to adopt a Resolution acknowledging Koretta McGhee for her service on the Human Relations Commission. Seconded by Mr. Weiss.

Mr. Ewald read the Resolution aloud for the record.

Motion Approved 7-0.

- B. Motion to adopt a Resolution acknowledging James Carminito for his four years of service on Borough Council.

Ms. Burckley made a Motion to adopt a Resolution acknowledging James Carminito for his four years of service on Borough Council. Seconded by Mrs. Vogel.

Mr. Ewald read the Resolution aloud for the record.

Motion Approved 7-0.

- C. Motion to adopt a Resolution acknowledging Richard Mark Kirkner for his eight years of service on Borough Council.

Ms. Dugan made a Motion to adopt a Resolution acknowledging Richard Mark Kirkner for his eight years of service on Borough Council. Seconded by Mrs. McGhee.

Mr. Ewald read the Resolution aloud for the record.

Motion Approved 7-0.

- D. Motion to adopt a Resolution acknowledging David Strenfel for his two years of service on Borough Council.

Mr. Weiss made a Motion to adopt a Resolution acknowledging David Strenfel for his two years of service on Borough Council. Seconded by Mr. Moore.

Mr. Ewald read the Resolution aloud for the record.

Motion Approved 7-0.

- E. Motion to adopt a Resolution for the sale and disposition of personal property valued at or below \$2,000.

Ms. Burckley made a Motion to adopt a Resolution for the sale and disposition of personal property valued at or below \$2,000. Seconded by Mr. Moore.

Motion Approved 7-0.

- F. Motion to adopt a Resolution appointing Tax Collection Committee (TCC) Delegates to the Chester County Tax Collection Committee (CCTCC).

Mr. Moore made a Motion to adopt a Resolution appointing Tax Collection Committee (TCC) Delegates to the Chester County Tax Collection Committee (CCTCC). Seconded by Ms. Burckley.

Motion Approved 7-0.

- G. Motion to adopt a Resolution authorizing the approval of a Blood Draw Policy Intermunicipal Memorandum of Understanding between the Borough of Phoenixville and Tower Direct, LLC, East Coventry, East Pikeland, East Vincent, West Vincent, West Pikeland and Schuylkill Townships and Spring City Borough.

Ms. Burckley made a Motion to adopt a Resolution authorizing the approval of a Blood Draw Policy Intermunicipal Memorandum of Understanding between the Borough of Phoenixville and Tower Direct, LLC, East Coventry, East Pikeland, East Vincent, West Vincent, West Pikeland and Schuylkill Townships and Spring City Borough. Seconded by Mr. Weiss.

On the Question:

Mr. Denlinger stated as the Council may know, a few months ago an individual escaped from custody. What you may not know is that it was during a blood draw at Phoenixville Hospital. Luckily, due to the great work of our Police Department, they were able to apprehend that individual, but that started the process of looking at the Borough's procedures. He explained one of the things that the State law allows for is for paramedics to come to our Police Department, for blood draws in certain circumstances. He explained the Borough is looking to engage with Tower Direct in order to have their paramedics come to department, to perform those blood draws. He stated that is part of the agreement, the Council is considering by Resolution this evening. Simultaneously the department has some fingerprinting and other specialized equipment that they allow surrounding municipalities to utilize, and those same municipalities are also interested in this program with Tower Direct. This interest in participating in the program then becomes an intermunicipal agreement, and there are certain legal requirements. He stated that he has worked on the agreement and stated each of the interested municipalities would have to adopt a similar Resolution in order to participate. He prepared the agreement with a myriad of things in mind and keeping the focus on protecting the

Borough from liabilities and including language that would ensure that if a prisoner from another municipality damages property the municipality would be responsible for any repairs.

Ms. Dugan asked if there are any additional costs associated with this.

Mr. Denlinger stated he believes there is a \$50 dollar fee but the chief may know better.

Chief Marshall explained the cost is around \$200 dollars and would be included as restitution on any citation the prisoner would receive.

Mr. Ewald stated the way he understands it is that the outside agencies would be the ones bearing the cost for their prisoners.

Motion Approved 7-0.

- H. Motion to adopt a Resolution accepting the sale of a 2008 Emergency One HP100 Foot Aerial Ladder Truck.

Mr. Weiss made a Motion to adopt a Resolution accepting the sale of a 2008 Emergency One HP100 Foot Aerial Ladder Truck. Seconded by Ms. Dugan.

On the Question:

Mr. Denlinger explained in December the Council authorized the sale and the Resolution tonight is needed to authorize the close of the sale.

Mr. Moore asked if there is any update on the vehicle purchase Staff has been pursuing to purchase.

Mr. Krack stated the ladder truck will not be sold until the new purchase has been received.

Motion Approved 7-0.

- I. Motion to schedule and advertise an Ordinance amending Chapter 13 (Licenses, Permits and General Business Regulations).

Ms. Burckley made a Motion to schedule and advertise an Ordinance amending Chapter 13 (Licenses, Permits and General Business Regulations). Seconded by Mrs. McGhee.

Mr. Denlinger explained Ordinance amendments are typically brought forward through the Policy Committee however, once or a twice a year due to timing issues the amendment doesn't go through committee and this is one of those

instances. He explained Chapter 13 part 13 deals with special events in the Borough, which includes the Inside Out program. As the program continues, the procedures need to be adapted from what has been learned in order to make sure that it is the best event for our community. In discussions with staff, there's a desire to adopt and implement some updated procedures from everything learned the past couple years. One of the most important things is that staff is able to make sure that ADA and emergency passages are kept open and in order to have some flexibility to do that, changes need to be made by Resolution. However, in order to make changes by Resolution, an ordinance is needed that allows the changes to be made by Resolution. The ordinance before us this evening allows for the changes by Resolution and is very procedural in manner, what will not skip the Policy Committee is the Resolution that adopts the actual conditions and regulations that are applied to the Inside Out and other special event programs.

Motion Approved 7-0.

XII. Reports of Committees, Boards, and Commissions

A. Historical and Architectural Review Board – Ms. Dugan

1. Motion to approve the Certificate of Appropriateness for renovations at 231-233 Bridge Street.

Ms. Dugan made a Motion to approve the Certificate of Appropriateness for renovations at 231-233 Bridge Street. Seconded by Ms. Burckley.

On the Question:

Ms. Dugan stated she asked to have this item moved from the Consent Agenda because this a large project in the downtown and she believes it is important that the Council pay attention to these types of things. She stated there were a few issues that needed to be worked through. The request was for some PVC materials to be used in the signage that is not approved by the HARB and its regulations. Signs with this material have been rejected previously, however the applicant was able to work this out and made appropriate changes.

Mr. Ewald stated he appreciates this being pulled from the consent agenda as this is one of the hallmark buildings. It definitely adds to the character of Bridge Street, and he feels it is good to highlight these projects when businesses are making these types of investments in the downtown.

Ms. Burckley stated she feels HARB did a great job of helping to bring this project forward while still adhering to the guidelines.

Ms. Dugan stated HARB did work out a lot of the issues, because the

board didn't want to give special, like, exemptions on things, and there are rules, that HARB wants to stick to them as much as they possibly can, because as soon as you break one of the rules, everybody else is going to want to break them as well.

Motion Approved 7-0.

- B. Planning Commission - Mr. Moore
- C. Phoenixville Regional Planning Committee – Mrs. McGhee
- D. Recreation Board – Ms. Dugan

Ms. Dugan reported on the current and upcoming programs and camps including winter intermural camps, Youth Volleyball, Jump Start Sports, Flag Football, yoga and pickleball.

- E. Tree Advisory Commission – Mr. Weiss
- F. Human Relations Commission – Ms. Burckley

XIII. Council Action referred from:

- A. Personnel and Public Safety Committee – Ms. Burckley
 - 1. No action to report.
- B. Parks and Recreation Committee – Mr. Moore
 - 1. No action to report.
- C. Infrastructure/Technology/Transportation/Sustainability Committee – Mr. Weiss
 - 1. No action to report.
- D. Finance Committee – Ms. Dugan
 - 1. No action to report.
- E. Policy Committee – Mrs. Vogel
 - 1. No action to report.

XIV. Public Comment - None

XV. Communications/Council Participation

Mr. Ewald explained based on the actions earlier in the agenda accepting the resignation, the Borough will be accepting applications from any members interested in serving in the vacancy now created in the North Ward can reach out to staff or myself. The vacancy will be for the remaining two years of the elected term.

XVI. Staff Reports are in the packets.

- A. Manager
- B. Police
- C. Fire
- D. Planning and Codes
- E. Public Works
- F. Finance
- G. Human Resources
- H. Recreation

XVII. Adjournment into Executive Session.

10.36 pm. Ms. Burckley made a Motion to Adjourn. Seconded by Mr. Weiss.

Mr. Ewald stated the Council will adjourn to discuss items regarding attorney-client privilege advice on Council communications and activities, and as well as a matter of real estate related to 17 Cromby Road.

E. Jean Krack
Borough Manager

Transcribed by: Jennifer Logan
Administrative Assistant
January 2026

PHOENIXVILLE BOROUGH COUNCIL - SPECIAL

Monday, February 9, 2026

7:00 PM

MINUTES

(Minutes approved by Borough Council on February 10, 2026)

- I. Pledge of Allegiance/Moment of Silence

- II. Roll Call
 - Mr. Ewald, President Present
 - Ms. Burckley, Vice President Present
 - Ms. Dugan Present
 - Mrs. McGhee Present
 - Mr. Moore Present
 - Mrs. Vogel Present
 - Mr. Weiss Present
 - Mr. Krack, Borough Manager Present
 - Ms. Getzfread, Asst. Borough Manager Present

III. Public Comment – None

IV. Communications/Council Participation - None

V. New Business

A. Interview candidates for the vacant North Ward Seat.

Ms. Klementina Budnik provided her background to Council and her desire to be appointed to the Vacant North Ward seat.

Questions were asked and answered.

Ms. Bailey MacDowell provided her background to Council and her desire to be appointed to the Vacant North Ward seat.

Questions were asked and answered.

Mr. Matthew Miller provided his background to Council and his desire to be appointed to the Vacant North Ward seat.

Questions were asked and answered.

Ms. Carolyn Treglia provided her background to Council and her desire to be appointed to the Vacant North Ward seat.

Questions were asked and answered.

VI. Adjournment at 8:57 pm by Mr. Ewald.

E. Jean Krack
Borough Manager

Transcribed by: Jennifer Logan
Administrative Assistant
February 2026

**Borough of Phoenixville
Council, Authorities, Bureaus, Commissions, and Agencies**

Planning Commission - 4 Year Term	Appointed	Reappointed	Term Expiration
Josh Gould	March 12, 2024		March 31, 2028
Raffaello DiNapoli	February 14, 2017	April 8, 2025	March 31, 2029
Amanda Irwin - Vice Chairperson	March 12, 2024		March 31, 2028
Catherine Bianco - Chairperson	March 9, 2021	March 11, 2025	March 31, 2029
Joseph Sikora	March 8, 2022		March 31, 2026
Thomas Carnevale	April 12, 2011	March 8, 2022	March 31, 2026
Jahan Tavangar	November 12, 2024		March 31, 2027
Brian Moore - Council Liaison			January 3, 2028

Zoning Hearing Board - 5 Year Term	Appointed	Reappointed	Term Expiration
Jonathan Steitzer	February 14, 2023		January 31, 2028
David Petty	October 10, 2023	January 9, 2024	January 31, 2029
Maureen Ahearn - Vice Chairperson	February 11, 2020	January 14, 2025	January 31, 2030
Bryan Emmanuel - Chairperson	April 10, 2018	January 13, 2026	January 31, 2031
Carolyn Treglia	April 9, 2024		January 31, 2027

Recreation Board - 4 YR Term	Appointed	Reappointed	Term Expiration
Kathy Gill - Vice-Chairperson	May 10, 2016	April 9, 2024	April 30, 2028
Vacant			April 30, 2028
Ed Lantzy	January 1, 2006	April 8, 2025	April 30, 2029
Joellen Nicholson	May 13, 2025		April 30, 2029
Janet Hunter - Chairperson	January 1, 2008	April 12, 2022	April 30, 2026
Allison Peffle	May 11, 2021	April 12, 2022	April 30, 2026
Dave Gill	May 10, 2010	March 14, 2023	April 30, 2027
Dana Dugan - Council Liaison	April 27, 2010		January 3, 2028

HARB - 4 Year Term	Appointed	Reappointed	Term Expiration
Brian Slater - Chairperson - Real Estate	September 11, 2007	August 13, 2024	August 31, 2028
William Felton - Contractor	August 13, 2013	August 12, 2025	August 31, 2029
Brandon Wertz	August 12, 2025		August 31, 2029
Joel Bartlett - Architect		August 8, 2023	August 31, 2027
Joseph Sikora - Planning Comm	January 12, 2023		March 31, 2026
Matthew McCloskey - BCO	September 12, 2023		N/A
Dana Dugan - Borough Council			January 3, 2028

Borough Council - 4 Year Term	Appointed	Reappointed	Term Expiration
Beth Burckley - Vice President	January 2, 2018	January 5, 2026	January 6, 2030
Dana Dugan	January 4, 2010	January 5, 2026	January 6, 2030
Jonathan Ewald - President	January 4, 2016	January 2, 2024	January 3, 2028
Koretta McGhee	January 5, 2026		January 6, 2030
Brian Moore - Assistant Secretary	January 6, 2020	January 2, 2024	January 3, 2028
Vacant			January 3, 2028
Tanya Vogel	January 5, 2026		January 6, 2030
Brian Weiss	January 6, 2020	January 2, 2024	January 3, 2028
Peter Urscheler - Mayor	January 2, 2018	January 5, 2026	January 6, 2030

Civil Service Commission - 6 YR Term	Appointed	Reappointed	Term Expiration
Mari Wineburg - Chairperson	September 14, 2021	August 8, 2023	January 31, 2028
Amara Thornton-Brown - Vice Chair	July 14, 2020	January 9, 2024	January 31, 2030
Beth Burckley	December 12, 2023		January 31, 2032
Alternate - J. D. Maloney	March 12, 2024		January 31, 2027
Alternate - Jeffrey Jones	January 14, 2025		January 31, 2029

Tree Advisory - 5 Year Term	Appointed	Reappointed	Term Expiration
Jennifer Chandler - Secretary	January 14, 2025	June 10, 2025	June 30, 2030
Susan Di Cerchio	July 12, 2022		June 30, 2027
Heidi Warning	June 10, 2025		June 30, 2029
Justin Gordon - Chairperson	August 13, 2024		June 30, 2028
Mary Foote	July 9, 2019		June 30, 2026
Brian Weiss			January 3, 2028

Human Relations - 3 Year Term	Appointed	Reappointed	Term Expiration
Kevin Zwick - Chairperson	September 10, 2024		March 31, 2026
Jasmine Joyner	May 13, 2025		March 31, 2026
Alexandra Moulton	November 12, 2025		March 31, 2028
Rev. Lee Paczulla	March 8, 2022	April 8, 2025	March 31, 2028
Linda Giovagnoli	November 12, 2025		March 31, 2027
Beth Burckley - Council Liaison			January 3, 2028

Other Appointments	Appointed	Reappointed	Term Expires
Emergency Management Coordinator Karin Williams	January 1, 2015		N/A
Vacancy Board Chairman Richard Kirkner	January 5, 2026		December 31, 2026

ORDINANCE NO. 2026 -

**BOROUGH OF PHOENIXVILLE
CHESTER COUNTY, PENNSYLVANIA**

“Special Event Regulations Ordinance”

AN ORDINANCE AMENDING THE CODE OF THE BOROUGH OF PHOENIXVILLE, CHAPTER 13 (LICENSES, PERMITS AND GENERAL BUSINESS REGULATIONS), PART 13 (SPECIAL EVENTS) TO AMEND SECTION 13-1301 TO PROVIDE FOR ALL SPECIAL EVENTS; AND FURTHER AMENDING PART 13 (SPECIAL EVENTS), SECTION 13-1303.2 IN ORDER TO ALLOW FOR PRIVATE PARTICIPATION IN BOROUGH-SPONSORED SPECIAL EVENTS; AND FURTHER AMENDEING PART 13 (SPECIAL EVENTS) TO AMEND SECTION 13-1304 TO ALLOW THE BOROUGH TO ADOPT ADDITIONAL CONDITIONS AND REGULATIONS PERTAINING TO SPECIAL EVENTS AS NEEDED.

The Council of the Borough of Phoenixville, Chester County, Pennsylvania, hereby
ORDAINS as follows:

SECTION I. - Amendment to Code

The codified Ordinances of the Borough of Phoenixville, Chapter 13 (Licenses, Permits and General Business Regulations), Part 13 (Special Events) is hereby amended to repeal and replace Section 13-1301 with the following new Section 13-1301 entitled “Purpose”:

§ 13-1301 Purpose.

The Borough Council finds that streets, public places and private facilities within the Borough are from time to time temporarily closed and used as sites for races, festivals, shows, neighborhood celebrations and other events that are open to the public. Events of this kind serve to improve the quality of life of the residents of the Borough and often result in large numbers of people congregating within the confines of the temporarily closed street, public places, facilities, and public right-of-way, and the resulting crowd conditions may create concerns for police and fire access and other control concerns related to health, safety, and welfare of the public and of persons and property in the designated area. It is therefore essential that a policy be established for regulating these Special Events to facilitate control over them by the sponsor and by the Borough to safeguard persons and property.

SECTION II. - Amendment to Code

The codified Ordinances of the Borough of Phoenixville, Chapter 13 (Licenses, Permits and General Business Regulations), Part 13 (Special Events), Section 13-1303, is hereby amended to repeal and replace Subsection 13-1303.2. as follows:

3. Any special event sponsored by the Borough, whether or not occurring exclusively on Borough property. Notwithstanding the foregoing, the Borough may allow non-Borough participation in certain Borough-sponsored events, in its sole discretion.

SECTION III. - Amendment to Code

The codified Ordinances of the Borough of Phoenixville, Chapter 13 (Licenses, Permits and General Business Regulations), Part 13 (Special Events) is hereby amended to repeal and replace Section 13-1304 with the following new Section 13-1304 entitled “Regulations”:

§ 13-1304 Regulations.

Borough Council may adopt by resolution, from time to time, additional conditions and regulations for Special Events permits impacting the Borough Right-of-Way, which may be separated into separate sets of conditions and regulations for specific types of Special Events. Such additional conditions and regulations may apply to permit holders, participants, and/or the general public.

SECTION IV. - Severability

The provisions of this Ordinance are intended to be severable, and if any section, sentence, clause, part or provision hereof shall be held illegal, invalid or unconstitutional by any court of competent jurisdiction, such decision of the court shall not affect or impair the remaining sections, sentences, clauses, parts or provisions of this Ordinance. It is hereby declared to be the intent of Borough Council that this Ordinance would have been adopted even if such illegal, invalid or unconstitutional section, sentence, clause, part or provision had not been included herein.

SECTION V. - Failure to Enforce not a Waiver

The failure of the Borough to enforce any provision of this Ordinance shall not constitute a waiver by the Borough of its rights of future enforcement hereunder.

SECTION VI. - Effective Date

This Ordinance shall take effect and be in force from and after its approval as required by the law.

SECTION VII. - Repealer

All other ordinances and resolutions or parts thereof insofar as they are inconsistent with this Ordinance are hereby repealed.

ORDAINED by Borough Council this 10th day of February, 2026.

By: _____
Jonathan M. Ewald
President, Borough Council

APPROVED by the Mayor, this 10th day of February, 2026.

By: _____
Peter J. Urscheler, Mayor

ENACTED, this 10th day of February, 2026.

By: _____
E. Jean Krack, Borough Manager/Secretary

I HEREBY CERTIFY that the foregoing is a true and correct copy of the said Ordinance duly adopted at a regular meeting of Borough Council held on the 10th day of February, 2026.

By: _____
E. Jean Krack, Borough Manager/Secretary

**BOROUGH OF PHOENIXVILLE
CHESTER COUNTY, COMMONWEALTH OF PENNSYLVANIA**

RESOLUTION NO. 2026 -

**A RESOLUTION ESTABLISHING CONDITIONS AND
REGULATIONS FOR THE PXV INSIDE-OUT SPECIAL
EVENT, PURSUANT TO SECTION 13-1304 OF THE
BOROUGH ORDINANCES.**

WHEREAS, Section 13-1304 of the Borough’s Codified Ordinances allows Borough Council to adopt additional regulations for special events by resolution; and

WHEREAS, pursuant to Resolution No. 2024-11, Borough Council established a seasonal special event known as “PXV Inside-Out” in the 100 and 200 blocks of Bridge Street on weekends from approximately Memorial Day Weekend through the first weekend in October, as further described in said Resolution as may be amended by further Resolution of Council from time-to-time (“PXV Inside-Out”); and

WHEREAS, since PXV Inside-Out constitutes a Borough-sponsored Special Event pursuant to Chapter 13 (Licenses, Permits and General Business Regulations, Part 13 (Special Events) of the Borough Ordinances, and because it occurs within the Borough right-of-way, Phoenixville Borough Council finds it to be in the best interest of the Borough, residents of the Borough, and the general public to promulgate additional conditions and regulations of participation therein.

NOW, THEREFORE, BE IT AND IT IS HEREBY RESOLVED by Phoenixville Borough Council, as follows:

1. Phoenixville Borough Council hereby approves and adopts the PXV Inside-Out Conditions and Regulations as described in Exhibit “A” attached hereto and incorporated herein, and authorizes all Borough personnel to implement the same as described therein.

2. Resolution No. 2024-11 shall remain valid in all respects, except where conflict is expressly contained herein, subject to further amendment by Council thereof.

APPROVED by Borough Council this 10th day of February, 2026.

By: _____
Jonathan M. Ewald
President, Borough Council

ENACTED this 10th day of February, 2026.

By: _____
E. Jean Krack, Borough Manager/Secretary

I HEREBY CERTIFY that the foregoing is a true and correct copy of the said Resolution duly adopted by a majority vote of the Borough Council at a regular meeting held on the 10th day of February, 2026 and said Resolution has been recorded in the Minutes of the Borough of Phoenixville and remains in effect as of this date.

By: _____
E. Jean Krack, Borough Manager/Secretary

EXHIBIT "A"
PXV INSIDE-OUT CONDITIONS AND REGULATIONS

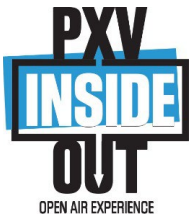

PXV INSIDE-OUT SPECIAL EVENT CONDITIONS AND REGULATIONS

PERMITTEE MAY COMMENCE SETUP OF OUTDOOR MERCHANDISE ON FRIDAYS ONLY AFTER BRIDGE STREET IS CLOSED AND COMPLETELY CLEAR OF ALL MOTOR VEHICLES AND BOROUGH STAFF

1. Permit / Application

- a. Any entity or person occupying a building fronting on the street(s) and block(s) of the PXV Inside-Out Special Event (hereinafter "PIO") street closures may utilize the closed street and right-of-way area directly in front of the building that they occupy ("Permit Area") in a manner so that such space is generally available to the public ("Participate/Participation"), subject to the conditions and regulations contained herein and other applicable laws, ordinances, and regulations.
- b. Any entity or person desiring to Participate in PIO, shall be required to complete an application and receive a permit from the Borough authorizing such Participation ("Permit").
- c. The Borough shall prepare and make available by the March 15th of each year a permit application for PIO, which shall include:
 - i. Applicant's eligibility to Participate shall be demonstrated;
 - ii. Contact person available at all times during PIO;
 - iii. Plan of use for the Permit Area;
 - iv. Indemnification requirements;
 - v. Insurance requirements;
 - vi. Acknowledgement of conditions and regulations; and
 - vii. Any other terms, conditions, and regulations deemed advisable by Borough staff.
- d. Permit Procedure.
 - i. No entity or person may participate in PIO without a valid PIO Permit and a valid permit ("SCSD Permit") issued in accordance with Chapter 13, Part 11 of the Borough's Ordinances (hereinafter "SCSDO").
 - ii. The Borough is not required to process any Permit application unless and until it is administratively complete, as determined by the Borough Director of Code Enforcement.
 - iii. The Borough shall make a determination on whether to grant or deny an application within thirty (30) days of the submission of an administratively complete Permit application.
 - iv. The Borough may include reasonable conditions as a part of the issuance of any Permit, which may be specific to a particular application, the compliance with which may be required prior to Participation in PIO.
 - v. Any person or entity issued a PIO Permit by the Borough shall hereinafter be referred to as a "Permittee".
- e. Eligibility. The following persons and/or entities shall be eligible to submit an application for a Permit to Participate in PIO:
 - i. An owner, tenant, or other occupant of a building fronting on the street(s) and block(s) closed for PIO.
 - (1) In the event that multiple eligible applicants apply for a PIO Permit from the same building, their respective Permit Areas shall be determined by the total square footage of the building occupied by each eligible applicant, divided by the total square footage of the building occupied by all eligible applicants.
 - ii. No owner, tenant, or other occupant of a building shall be eligible for a Permit where such building, or any such owner, tenant, or occupant, is subject to: (i) a past-due municipal bill or fee, or (ii) subject to an ongoing violation of the Borough's ordinances (such as a property maintenance or zoning ordinance violation).

2. Further Procedures:

- a. The Borough Police Department and Borough Fire Department may create, separately or together, emergency management services policies and procedures, which shall be supplemental to the terms and conditions contained herein.
- b. In any emergency situation, the terms and conditions of the PIO may be suspended until, in the Borough's opinion, such emergent situation is resolved.

3. Outdoor Sales of Food/Alcohol and Merchandise of Existing Businesses:

- a. During PIO, the consumption of alcohol within each Permit Area is permitted until 10:00 pm Fridays, Saturdays and Sundays, subject to 3.b., below.
- b. The sale and/or distribution of alcohol for on-site consumption by Permittees shall be subject to Permittee having a valid license to do so issued by the Pennsylvania Liquor Control Board, and any and all such sale and/or distribution shall be operated in accordance with all laws, rules and regulations of the Pennsylvania Liquor Control Board and any other entity having jurisdiction thereover. Proof of compliance with the foregoing shall be provided to the Borough upon request.

4. Requirements and Conditions:

- a. Permittee must maintain a general liability insurance. The Borough must be named as an additional insured on these policies, and proof of insurance must be provided to the Borough. Permittee agrees to indemnify, defend, and hold harmless the Borough, its employees, officers, contractors, and agents against any and all claims or suits for damages or injury arising out of PIO.
- b. The business must comply with all applicable laws relating to litter, noise, and other livability matters.
- c. Permittee must maintain a clear path for emergency vehicles along the center of Bridge Street. No displays, merchandise, tables or structures should be placed within eight (8) feet on either side of the center line of Bridge Street.
- d. Permittee must maintain a clear path on the sidewalks for pedestrian ADA access, in accordance with the requirements imposed by SCSDO.
- e. All areas must comply with all applicable provisions of the fire code.
- f. The PIO Permit must be posted on the premises so as to be visible from the public right-of-way during the hours of operation of the PIO.
- g. The Permittee shall remove the sidewalk portion of the PIO setup of tables, chairs and other furnishing within one (1) hour after verbal notice to the Permittee, authorized representative, or any other operator affiliated therewith by the Borough, if in the Borough's sole discretion it is determined that the PIO setup is detrimental to the health, safety and general welfare of the Borough or its citizens because one or more of the following conditions has occurred:
 - Due to emergency access changes, the Permit Area setup narrows the emergency access area to the extent that emergency access is impeded;
 - The Permit Area interferes with the maintenance or installation of an underground utility structure
 - The Permit Area is no longer being used as such;
 - The Permit Area has been temporarily or permanently closed for violation of any Borough, county, state or federal law and/or regulation;
 - The Permit Area is operated in violation of any ordinance, rule or regulation of the Borough of Phoenixville.
- h. Permittees may provide one (1) 10 x 10 pop-up tent for their business operations. Furnishings for Permit Areas shall consist solely of movable tables, chairs and decorative accessories. Furnishings must be kept in a state of good repair and in a clean and safe condition at all times. No plastic furniture will be allowed. All furniture must be approved by the Borough.
- i. The width of the Permit Area must not exceed the width of the frontage of the business' property on the area dedicated to PIO.
- j. Outdoor Dining or sales of merchandise must not interfere with any utilities or other facilities, obstruct any required clearance for entrances or exits, obstruct any areas required for accessibility for disabled persons.
- k. Tables, chairs, and all other furnishings or accessories may not be left in place outside Permit Area hours, but shall be either stored indoors or stacked and stored in an orderly fashion adjacent to the structure. Tables, chairs or any other furnishings used in connection with an Permit Area shall not be attached, chained or in any manner affixed to any tree, post, sign or other Borough-owned fixture.

5. Penalties / Enforcement

- a. Penalties. Penalties for failure to comply with these Conditions and Regulations and/or any conditions of any issued PIO Permit shall be enforced in the manner provided for in the SCSDO. In addition thereto, at the discretion of the Borough, three (3) or more violations by a single Permittee

in any calendar year may result in revocation of such Permittee's Permit.

- b. Persons Authorized to Enforce. These Conditions and Regulations and/or any conditions of any issued PIO Permit may be enforced by the Borough Manager and/or their designee(s), including without limitation, the Borough Codes Department, Fire Department, Parking Department, and Police Department.



EXISTING EXTERIOR PHOTOS

MAIN STAY INN

SCHEMATIC PHASE - 2/2/26

RA. HOFFMAN ARCHITECTS INC.
55 PLANK AVENUE, PAOLI, PA 19301
(810) 889-0880 FAX (810) 889-0883



EXTERIOR PERSPECTIVE

MAIN STAY INN
SCHEMATIC PHASE - 2/2/26

R.A. HOFFMAN ARCHITECTS INC.
55 PLANK AVENUE, PAOLI, PA 19301
(610) 889-0660 FAX (610) 889-0663



EXISTING EXTERIOR PHOTOS

MAIN STAY INN

SCHEMATIC PHASE - 2/2/26

R.A. HOFFMAN ARCHITECTS INC.

55 PLANK AVENUE, PAOLI, PA 19301
(610) 889-0660 FAX (610) 889-0663



BRIDGE ST. ELEVATION

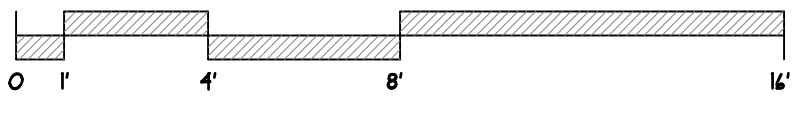

MAIN STAY INN
SCHEMATIC PHASE - 2/2/26

R.A. HOFFMAN ARCHITECTS INC.
55 PLANK AVENUE, PAOLI, PA 19301
(610) 889-0660 FAX (610) 889-0663



EXISTING EXTERIOR PHOTOS

MAIN STAY INN
SCHEMATIC PHASE - 2/2/26

R.A. HOFFMAN ARCHITECTS INC.
55 PLANK AVENUE, PAOLI, PA 19301
(610) 889-0880 FAX (610) 889-0883



S. MAIN ST. ELEVATION

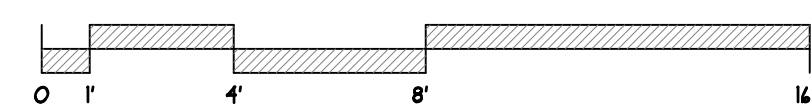

MAIN STAY INN
SCHEMATIC PHASE - 2/2/26

R.A. HOFFMAN ARCHITECTS INC.
55 PLANK AVENUE, PAOLI, PA 19301
(610) 889-0660 FAX (610) 889-0663



EXISTING EXTERIOR PHOTOS

MAIN STAY INN

SCHEMATIC PHASE - 2/2/26

R.A. HOFFMAN ARCHITECTS INC.
55 PLANK AVENUE, PAOLI, PA 19301
(610) 889-0660 FAX (610) 889-0663



REAR ELEVATION

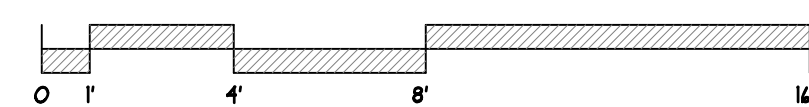

MAIN STAY INN
SCHEMATIC PHASE - 2/2/26

R.A. HOFFMAN ARCHITECTS INC.
55 PLANK AVENUE, PAOLI, PA 19301
(610) 889-0660 FAX (610) 889-0663

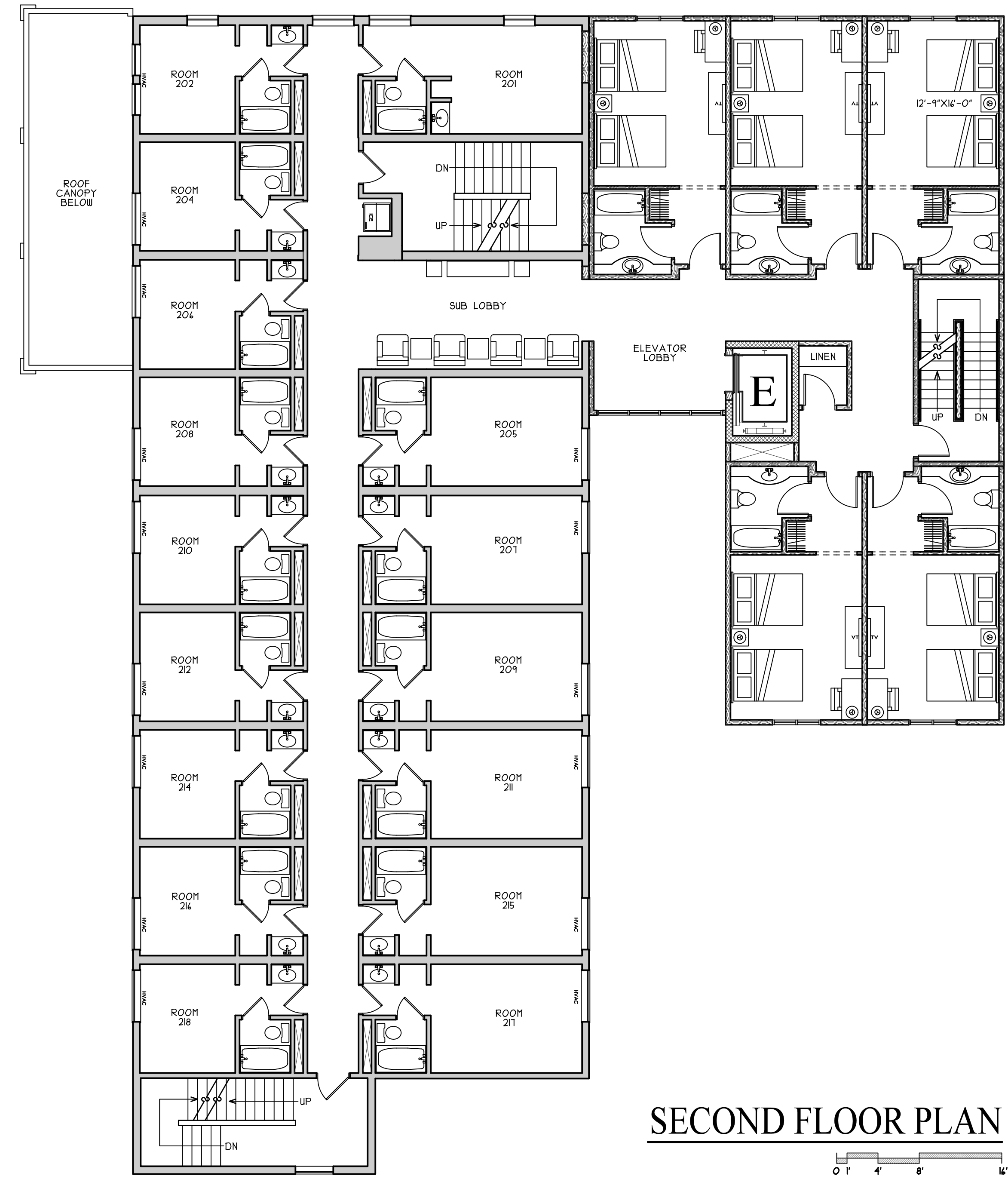
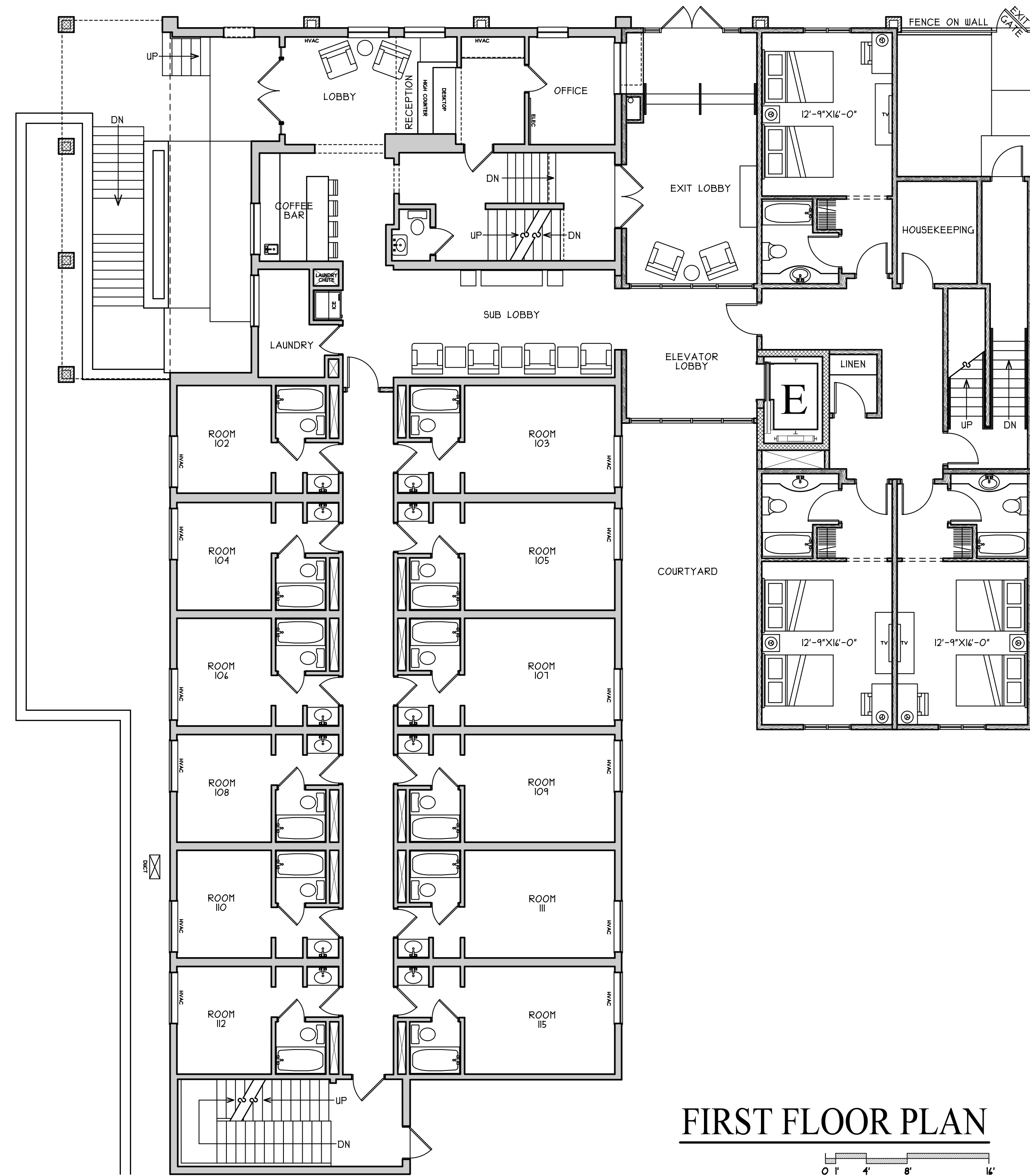

MAIN STAY INN
SCHEMATIC PHASE - 2/2/26

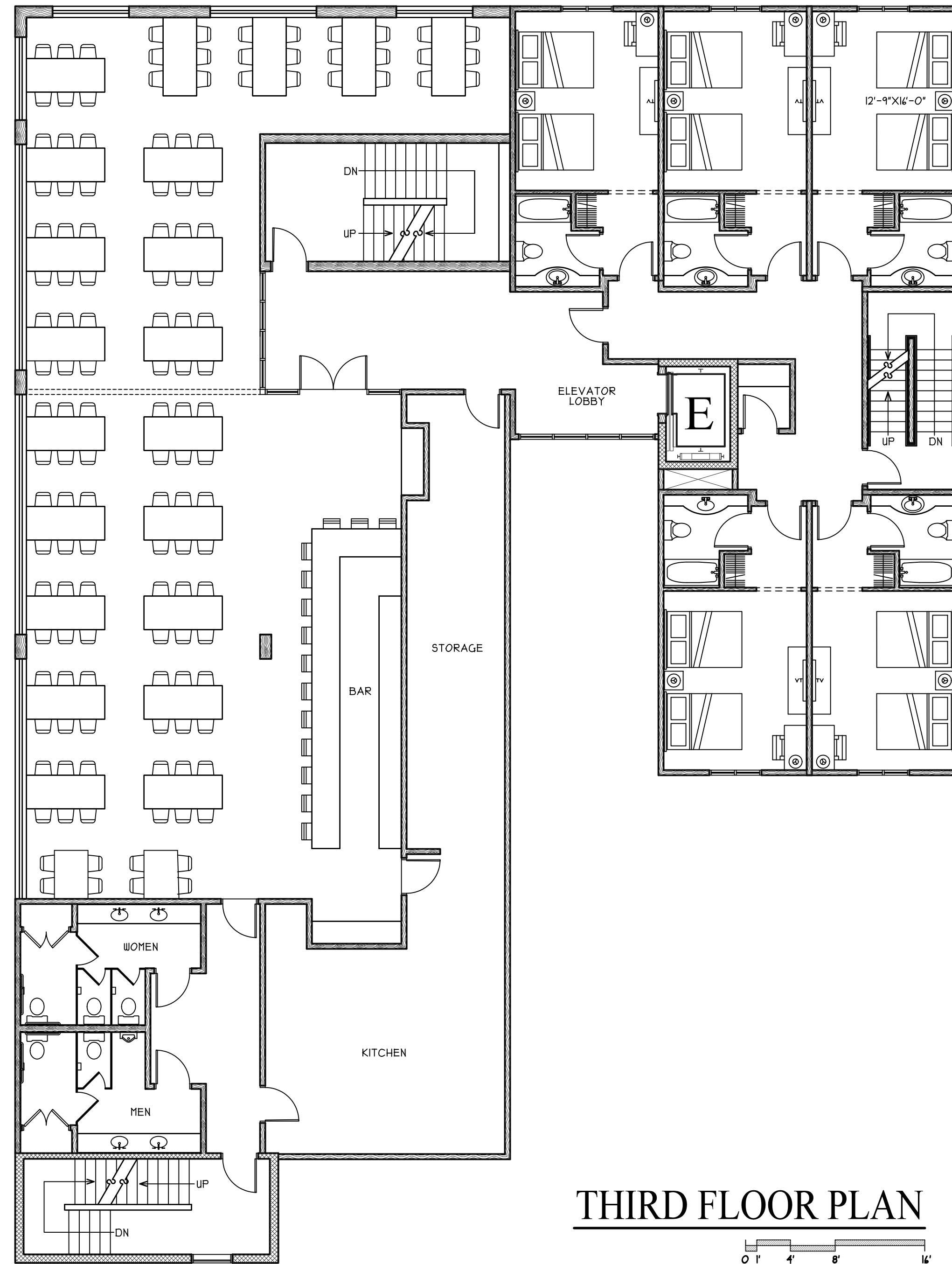

THIRD FLOOR PLAN

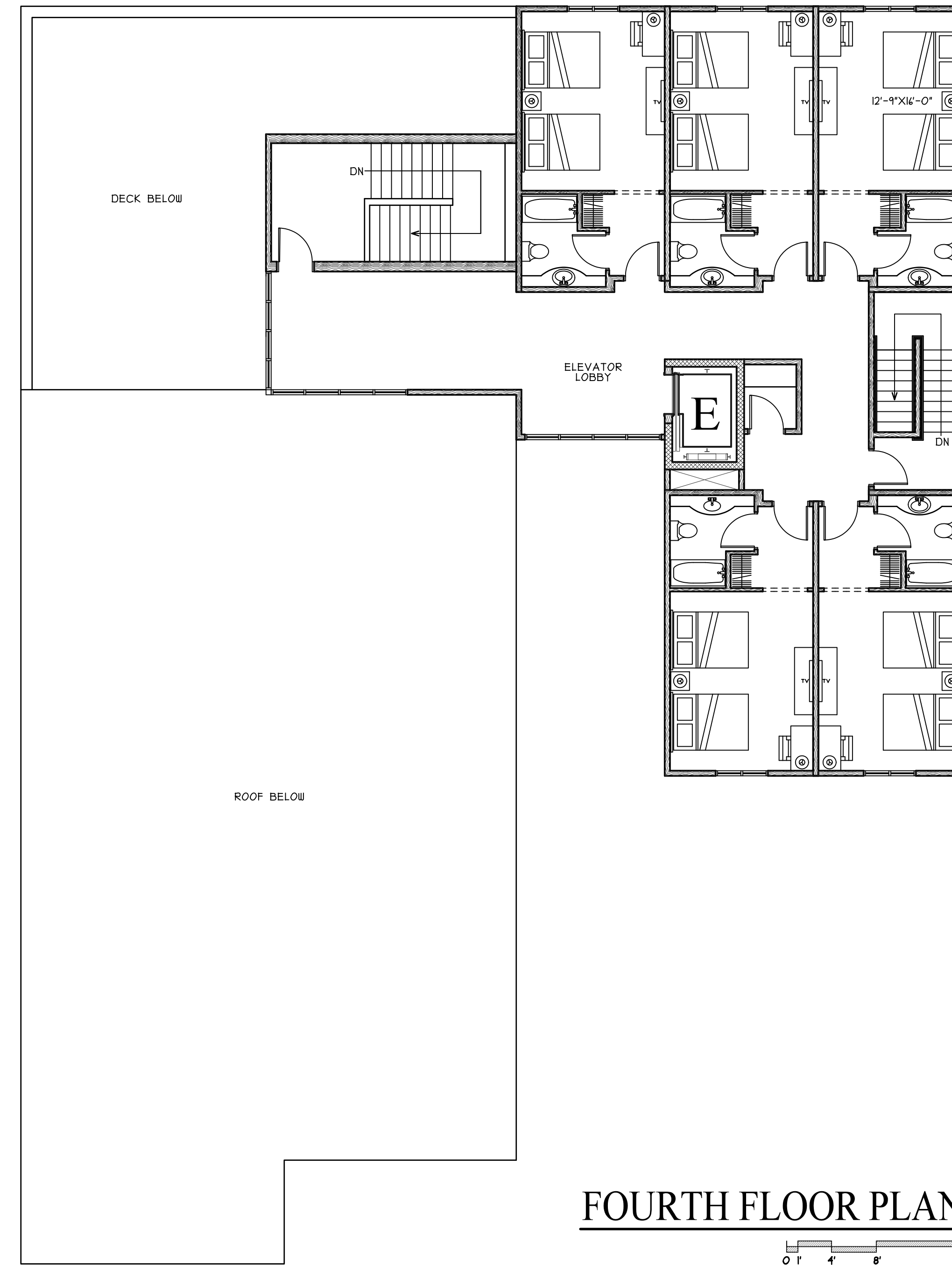

FOURTH FLOOR PLAN

MAIN STAY INN
 SCHEMATIC PHASE - 2/2/26

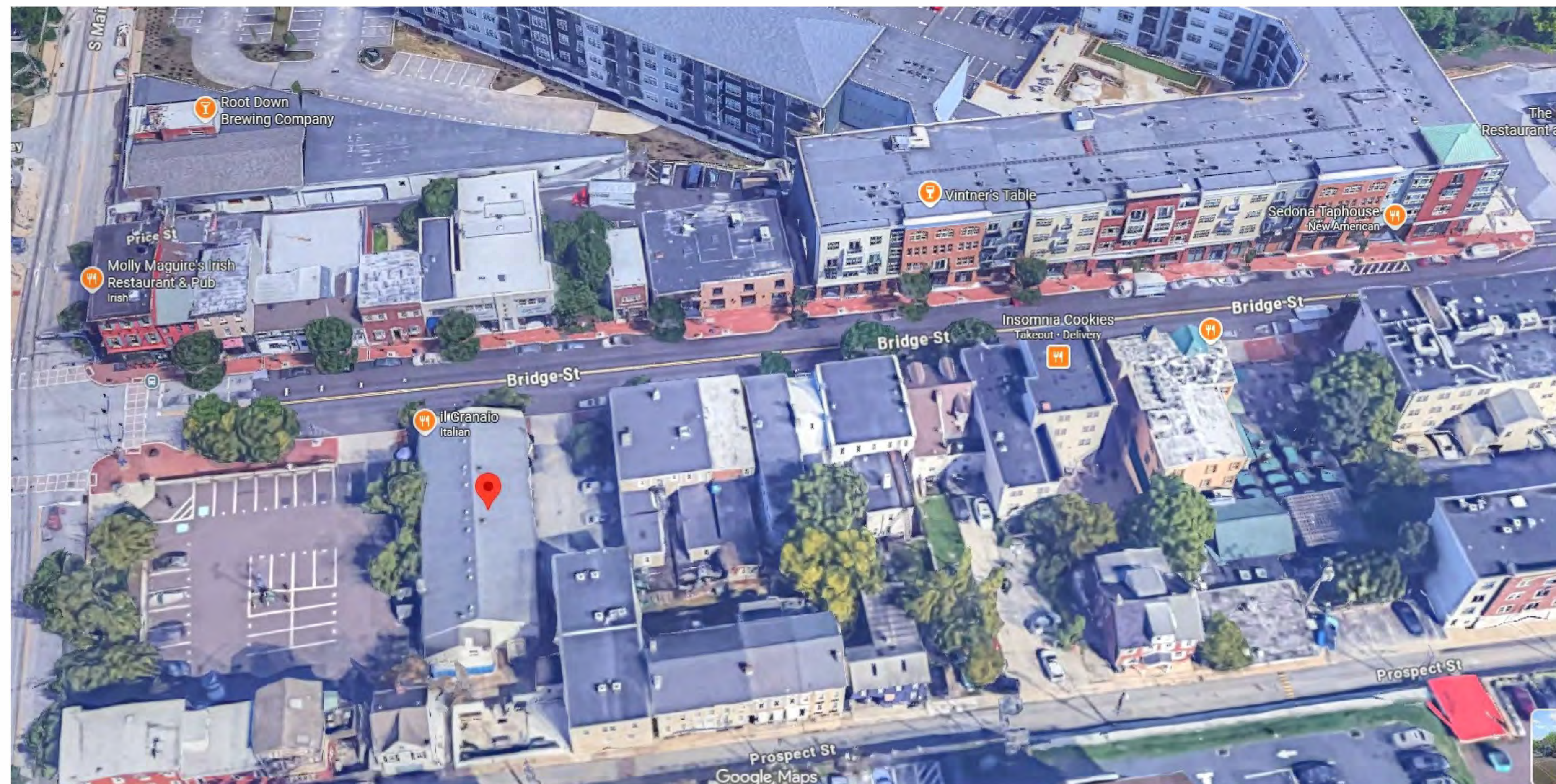
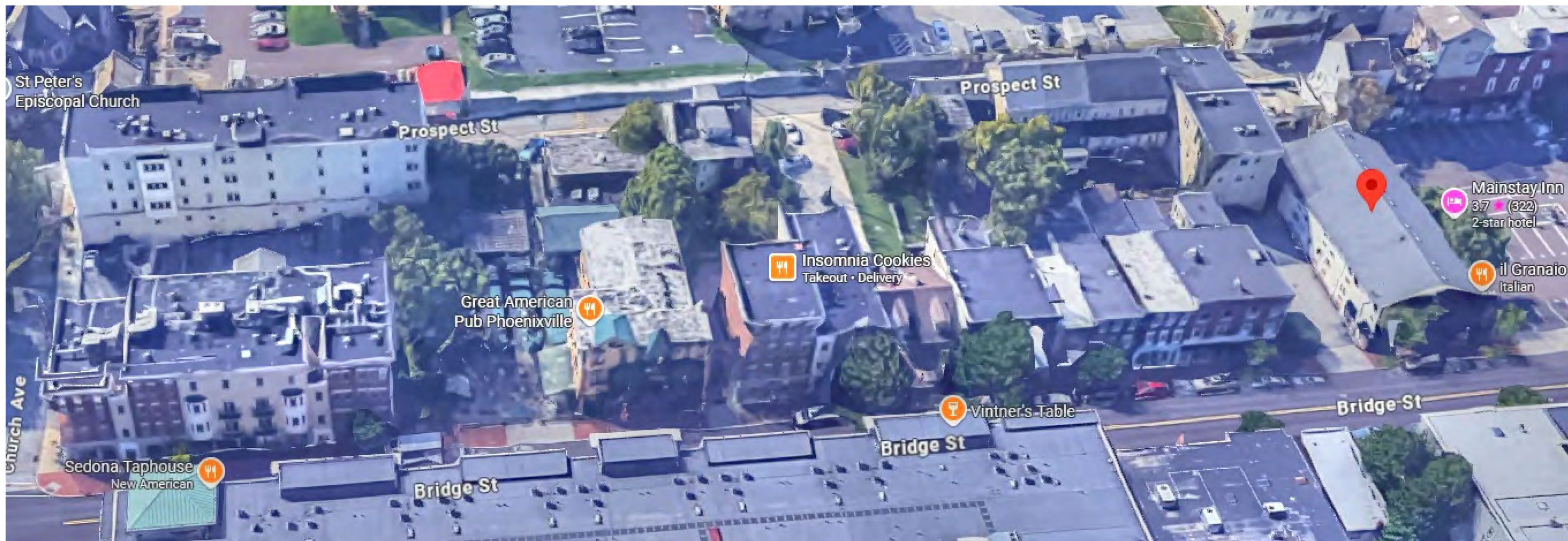

EXISTING EXTERIOR PHOTOS

MAIN STAY INN
 SCHEMATIC PHASE - 2/2/26

R.A. HOFFMAN ARCHITECTS INC.
 55 PLANK AVENUE, PAOLI, PA 19301
 (610) 889-0660 FAX (610) 889-0663



EXISTING EXTERIOR PHOTOS

MAIN STAY INN

SCHEMATIC PHASE - 2/2/26

RA. HOFFMAN ARCHITECTS INC.
55 PLANK AVENUE, PAOLI, PA 19301
(610) 889-0860 FAX (610) 889-0863

400 SERIES DOUBLE-HUNG WINDOW



Interior

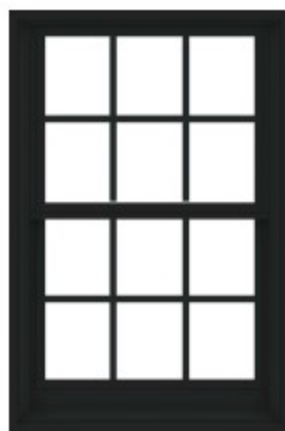

Exterior

Summary

Product ID#	TW2436
Unit Width	29 5/8"
Unit Height	44 7/8"
Interior Color	White
Glass	Low-E4® Glass
Hardware	Standard Lock and Keeper, White

Optional Hardware None

Grille Pattern Colonial

Grille Width 3/4"

Exterior Color Black

Exterior Trim Profile None

Exterior Trim Color Black

Feedback



STOREFRONT SUBFRAME FOR TRIFAB® 451

STAY AHEAD OF THE BUILD
WITH FLEXIBLE INSTALLATION

INSTALLATION
FLEXIBILITY

ACCOMMODATES
SINGLES OR PAIRS
OF DOOR

TEMPORARY DOOR
COMPATIBILITY

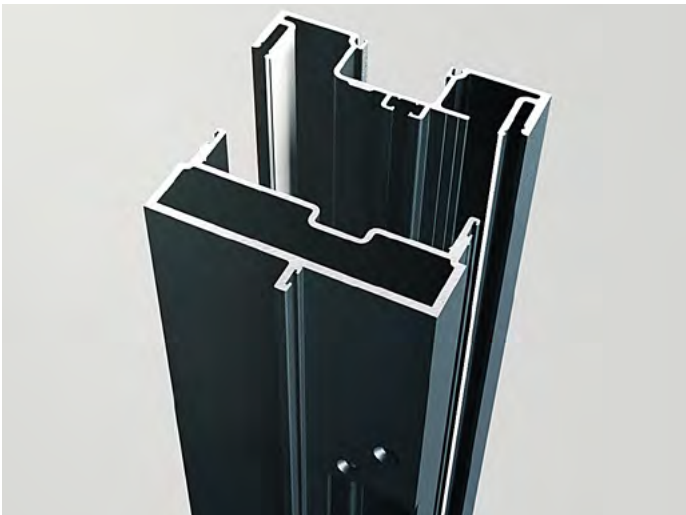
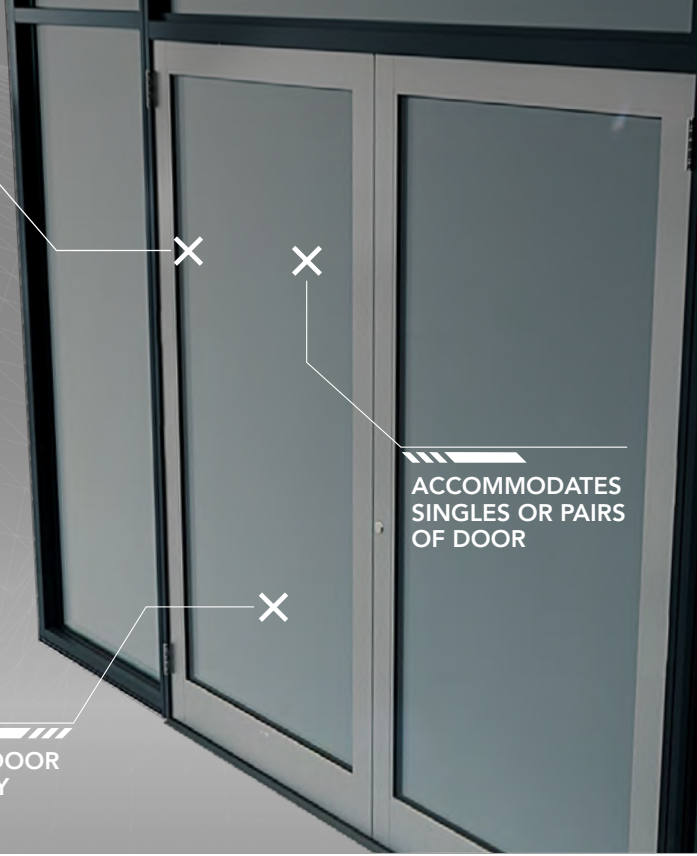

Designed for commercial storefront projects, the Storefront Subframe for Trifab® 451 has been engineered to provide the flexibility needed to keep projects on schedule.

As the first and only commercial storefront solution that enables phased door installation, the system allows storefront framing, sidelites, and transoms to be installed independently of doors and hardware. This separation ensures that projects can adapt to schedule changes and site delays while maintaining high-performance standards.

INNOVATION ENGINEERED

The patented two-piece male/female jamb system delivers reliable performance and tested durability:

- Reduces delays that can be caused by complex entrance components and systems
- Simplifies sequencing across trades through phased installation
- Allows early framing installation while protecting final entrances from damage
- Maintains project momentum with temporary doors or coverings that protect openings during construction and help secure an earlier certificate of occupancy
- Accommodates variable door and transom heights, singles or pairs, with or without transoms

This innovative design allows critical storefront work to advance without waiting for final door components, streamlining jobsite coordination and instilling confidence in project delivery.

FLEXIBLE INSTALLATION, MAXIMUM EFFICIENCY

The Trifab® 451 Subframe provides a large temporary opening that allows glazing and adjacent trades to progress safely, while final doors and hardware can be installed later. By phasing the installation, projects can move forward efficiently without compromising performance or aesthetic standards.

Wesley 2 Light LED Wall Light Architectural Black
49279BKLED (Black)

Project Name: _____
 Location: _____
 Type: _____
 Qty: _____
 Comments: _____



Certifications/Qualifications

Location Rating	Wet
	www.kichler.com/warranty

Dimensions

Base Backplate	5.50 X 4.25
Extension	4.00"
Weight	3.70 LBS
Height from center of Wall opening (Spec Sheet)	7.00"
Height	13.75"
Width	7.00"

Photometrics

Color Rendering Index	90
Delivered Efficacy (Lumens/Watt)	37
Delivered Lumens	700
Kelvin Temperature	3000K

Primary Lamping

Expected Life Span	40000
Lamp Included	Integrated
Light Source	LED
Max or Nominal Watt	20W
# of Bulbs/LED Modules	2





Product/Ordering Information

SKU	49279BKLED
Finish	Black
Style	Contemporary
UPC	7.83928E+11

Specifications

Diffuser Description	Clear Tempered Glass
Material	ALUMINUM

Additional Finishes

-  Black
-  Platinum
-  Textured Architectural Bronze
-  White

AEL-42 PTAC APPLICATION

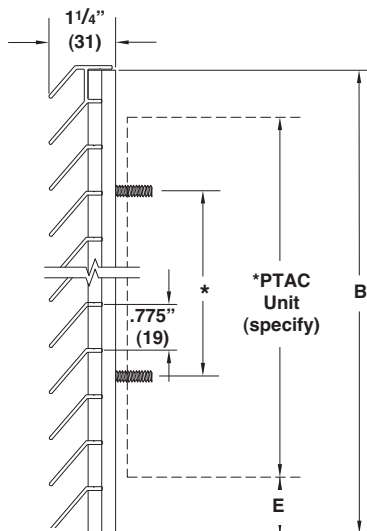
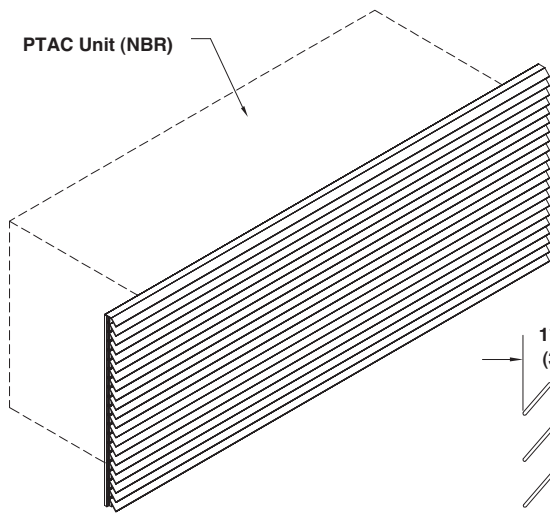
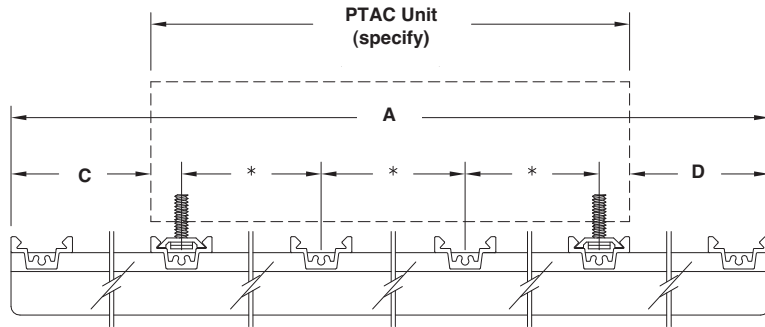

STANDARD CONSTRUCTION

- Extruded aluminum; 6063-T5
- 42° architectural decorative louver PTAC thru wall application

OPTIONS

- Clear or anodized finish
- Prime coat
- Baked Enamel (Kynar 50%)
- Pearledized 50 or 70
- Kynar 70%
- .040 (1) aluminum sheet
- .040 (1) aluminum (1 side) with 1" (25) insulation
- .040 (1) aluminum (2 sides) with 2" (51) insulation
- Other blankoff required
- Exterior mounting holes as required
- See AEL frames for perimeter frame options

VARIATIONS

- External drains
 - Using drain kits
- Internal drains
 - No drain holes in rear of louver
 - Drain holes for PTAC emergency over flow
- Unit type _____
- Model _____

Notes:

1. Face view for illustration purposes only.
 2. Dimension "E" = bottom of louver to bottom of PTAC cabinet.
 3. Dimensions in inches, parenthesis () indicate millimeters.
- *Dimensions determined by unit, model, and type.

UNIT TYPE	UNIT MODEL NO.	ACTUAL SIZE					VARIATIONS
		A	B	C	D	E	
PROJECT ARCH./ENGR. REPRESENTATIVE	 WebREPS 1-800-810-3280	LOCATION CONTRACTOR DATE					

Personnel and Public Safety Committee Meeting
Tuesday, February 3, 2026
6:00 pm

MINUTES

Committee: Chairperson, Ms. Burckley, Mr. Ewald, and Mrs. McGhee
Mayor Urscheler

Staff: Mr. Krack Ms. Getzfread, Chief Marshall, Chief Brazunas, Deputy Chief Wagner –
TowerDIRECT

- I. Call to Order at 6:00 pm
- II. Public Comment on Non-Agenda Items.

Ms. Burckley read a clarification statement from Mayor Urscheler regarding the role of the Phoenixville Borough Police Department in Immigration Enforcement.

Chief Marshall provided background on the incident earlier in the day as it relates to Immigration and Customs Enforcement (ICE) officers taking two individuals into custody. He also restated the clarification statement from the Mayor.

Residents and non residents expressed various levels of concern about the incident earlier in the day and questioned the Borough's leadership in response to ICE related incidents. There were also numerous thoughts and recommendations on how to improve efforts to allay concerns from residents when ICE activity occurs in the Borough.

Those participating in Public Comment included:

Anna Cephus, Nick Vessi, Rhona Candeloro, Shayna Miller, Maurene Rietmiller, Marilyn Harvey, James Brower, Alex Kearns, Olivia McIntyre, Rebecca Pultork, Jacob Month, Stephanie Nicolosi, Rosa Davilo, Sarah Howell, Adeline Smith, Dana Waldman Ginger Murphy, Drena Burbaker, Vince McDevitt, Megan Connelly, Rebecca Seglem Saude Rijas, Lillian Acosta, Rosa Davilo, Henrik, Alec Kearns, Shelia Cork, Allie Burger, and James Brower

Ms. Burckley closed public comment and stated the committee and staff would coalesce the information to see what response can be provided at a later time. She reiterated this committee and Borough Council are the appropriate venues to bring such matters or concerns to the attention of Borough Council and Staff.

- III. Committee Member Updates/Discussions.

Ms. McGhee thanked Ms. Getzfread for providing the past survey results.

IV. New Business

A. Review of monthly Police, Fire and Ambulance Reports.

Chief Marshall reported there were 22 applicants taking the next Civil Service Test this coming weekend.

Chief Brazunas reported the Quint fire apparatus should arrive tomorrow and Ladder 65 will be sold next week. He reported three new firefighters will be sworn in at the Borough Council meeting next week and will also include the new Medical Director.

B. Call for Residents interested in being appointed to various Boards and Commissions.

Ms. Burckley encouraged residents to consider applying for positions on various boards and commissions.

V. Old Business

A. PXV Inside Out.

Ms. Burckley stated new regulations will be considered at the Borough Council meeting next week and Staff is preparing for the 2026 season.

B. Emergency Management.

Ms. Burckley stated there was nothing new to report.

C. Community Policing.

Ms. Burckley stated there was nothing new to report.

D. Retention/Recruitment Update

Ms. Burckley stated Staff continues to review where Borough employees stand in relation to other communities of like size.

VI. Public Comment

There was no public comment.

VII. Adjournment at 7:37 by Mr. Ewald.

Next Meeting Date: Tuesday, March 3, 2026, at 6:00 pm

Parks and Recreation Committee Meeting
Tuesday, January 20, 2026
6:00 pm

MINUTES

Committee: Chairperson, Mr. Moore, Ms. Dugan, Mrs. McGhee, and Mr. Weiss

Public Members: Janet Hunter

Staff: Mr. Krack, Ms. Gibbons, Ms. Getzfread, Ms. Strunk, and Mr. Watson

I. Call to Order at 6:04 pm. Mr. Weiss arrived at 6:19 pm

II. Public Comment on Non-Agenda Items

There were no public comments.

III. Presentations

There were no presentations.

IV. Committee Member Updates/Discussions

Mr. Moore as Staff to clarify how fees are adjusted for temporary community events. Ms. Getzfread provide information on how Staff works with each applicant to ensure both sides are aware of how the fees are calculated.

V. New Business

A. Review of Quarterly Recreation Board reports (Jan, Apr, Jul, & Oct only).

Ms. Hunter stated there is no report as the Board will not meet until Monday, January 26.

B. Motion to recommend Borough Council approve a Temporary Community Event Application for First Fridays on Friday, May 1, June 5, July 3, August 7, September 4, October 2, November 6, and December 4, 2026 from 5:30 pm to 8:30 pm on the 100 and 200 Block of Bridge Street and the Bridge and Main Street Parking Lot. Bridge Street to be closed between Gay Street to Main Street and Main Street to Starr Street from 2:00 to 10:00 pm. The Bridge and Main Street Parking Lot to be closed from 8:00 am to 10:00 pm on each Friday.

Ms. Dugan made a Motion to recommend Borough Council approved the events as presented. Second by Ms. McGhee.

On the question: Ms. Getzfread provided an update on the First Friday events and the request from business owners to allow for the closure of Main Street as well. Staff recommends Main Street only be closed during those events which occur in June through October.

Ms. Dugan amended her motion to include Staff's recommendation. Second by Ms. McGhee. Motion approved 3-0.

- C. Motion to recommend Borough Council approve a Temporary Community Event Application for WuFF Jam 2026 on Saturday, September 19, 2026, from 11:00 am to 5:00 pm in Reeves Park. Third Avenue between Main Street and B Street to be closed from 7:00 am to 5:00 pm. Conditioned upon receipt of valid Certificate of Insurance naming Borough as Additional Insured.

Ms. McGhee made a Motion to recommend Borough Council approve the event as presented. Second By Mr. Weiss. Motion approved 4-0.

- D. Review new GIS Mapping

VI. Public Comment

There was no public comment.

VII. Adjournment at 6:21 by Ms. McGhee.

Next Meeting Date: Tuesday, February 17, 2026, at 6:00 pm.

Policy Committee Meeting
Tuesday, January 27, 2026
Immediately following Finance Committee
Meeting which starts at 5.30 pm

MINUTES

Committee: Chairperson, Ms. Vogel, Mr. Ewald, and Ms. Burckley
Staff: Mr. Krack and Mr. Boelker

I. Call to Order at 5:55 pm.

II. Public Comment on Non-Agenda Items

There was no public comment.

III. Committee Member Updates/Discussions

There were no updates or discussion.

IV. New Business

A. Motion to recommend Borough Council schedule and advertise an Ordinance amendment to Chapter 1 “Administration and Government”.

Ms. Burckley made a Motion to recommend Borough Council schedule and advertise the ordinance amendment as presented. Second by Mr. Ewald. Motion passes 3-0.

B. Motion to recommend Borough Council schedule and advertise an Ordinance amendment to Chapter 15 “Motor Vehicles”.

Ms. Burckley made a Motion to recommend Borough Council schedule and advertise the ordinance amendment as presented. Second by Mr. Ewald. Motion passes 3-0.

C. Motion to recommend Borough Council schedule and advertises an Ordinance amendment to Chapter 27 “Zoning”.

Ms. Burckley made a Motion to recommend Borough Council schedule and advertise the ordinance amendment as presented. Second by Mr. Ewald. Motion passes 3-0.

- D. Motion to recommend Borough Council adopt a Resolution Establishing Conditions and Regulations for the PXV Inside-Out Special Event, Pursuant to Section 13-1304 of the Borough Ordinances.

Ms. Burckley made a Motion to recommend Borough Council approve the resolution as presented. Second by Mr. Ewald. Motion passes 3-0.

- V. Old Business

There was no old business.

- VI. Public Comment

There was no public comment.

- VII Adjournment at 6:12 pm by Ms. Burckley.

Next Meeting Date: Tuesday, February 24, 2026, immediately following the Finance Committee which starts 6:00 pm.

**INFRASTRUCTURE, TECHNOLOGY, TRANSPORTATION,
AND SUSTAINABILITY (ITTS)
COMMITTEE MEETING
Tuesday, January 20, 2026
immediately following the Parks and
Recreation Committee which starts at 6:00 pm.**

MINUTES

Committee: Chairperson, Mr. Weiss, Mrs. McGhee, and Mr. Moore
Staff: Mr. Krack, Mr. Watson, and Ms. Getzfread

I. Call to Order at 6:31 pm

II. Public Comment on Non-Agenda Items

There were no public comments.

III. Committee Member Updates/Discussions

Ms. McGhee introduced as the newest Councilperson on the Committee.

IV. New Business

There was no business.

V. Infrastructure

A. Engineering Reports (Jan, Apr, Jul, Oct only)

Mr. Weiss acknowledged receipt of the reports and asked if there were any questions. There were none.

B. Stormwater Management

Mr. Krack reported there has been no updates from the Commonwealth on any grant awards to date.

C. Phoenix Wheel

Mr. Krack reported Staff has set a Ribbon Cutting for Saturday, June 6, 2026 at 10:00 am. More information will follow. Work continues to progress on the installation with expectation the project will be completed by end of April.

D. Borough Properties and Habitat for Humanity

Mr. Krack reported he has an upcoming meeting with Habitat as it relates to the review of the project and the preparation of documents needed to transfer the two properties from the Borough to Habitat.

VI. Transportation

A. Bridge and Starr Street

Mr. Krack reported all grant contracts have been received and all PennDOT permits have been approved. Staff will meet with the Borough Engineer later in the week to finalize documents in preparation of bid documents with expectation of awarding the project contract at the April borough Council Meeting.

B. Paradise Street – Phase 2

Mr. Krack reported the grant contract is being prepared and all PennDOT permits have been approved. The Borough Engineer expects to finalize documents in preparation of bid documents with expectation of awarding the project contract at the April borough Council Meeting.

C. Bridge and Nutt – 23 Corridor Improvements

Mr. Watson reported the signalization phase of the project is ongoing. He expects the construction activity will occur once the weather breaks in the spring.

D. Trails – Fillmore Street Tunnel Inspection

Mr. Krack provided a summary of the engineer's report and that no action is necessary at this time. The Borough Engineer recommends continuing to monitor and report every two years.

E. Starr Street (SR 0029) and 2nd Avenue Project

Mr. Krack reported the engineer has started the topography review to assess water flow into the area as needed for the design and engineering of the project.

F. No Right Turn on Red in Downtown.

Mr. Krack reported the police department had provided crash data to the engineer earlier in the week.

G. Crosswalks at St Mary's Street and Dayton Avenue.

Mr. Krack reported Staff has prepared an ordinance to establish all-way stop signs at the intersection. Mr. Watson reported he is waiting for proposals for the construction of the needed ADA ramps.

VII. Sustainability

A. PXVNEO

Mr. Watson reported the concrete slab was installed and that other preparatory work was being done. He stated the equipment was now enroute from overseas but no specific delivery time has been provided.

B. Solar Installation - Rec Center

Mr. Krack reported the engineer has provided a request for qualifications and that Staff is working with the County with regard to the needed grant contract. Staff expects the project will start in the spring.

VIII. Technology Updates

A. Monthly Reports

Mr. Weiss acknowledged receipt of the reports and asked if there were any questions. There were none.

B. Review new GIS Maps

Mr. Krack reported there has been numerous updates to the maps and encouraged committee members to look at them and provide any feedback.

IX. Public Comment

Mr. Saneck asked what the status was of the Fillmore Street relocation project. Mr. Krack stated the Borough did not receive the grant it was seeking and that the project would likely stop at this time. He stated Staff will look at the possibility of doing a mill and overlay project for the portion of the street between Franklin Avenue and South Street.

Sally Doyle noted the Green Team was working on a date for cleanup opportunities.

X. Adjournment at 7:19 pm by Ms. McGhee.

Next Meeting Date: Tuesday, February 17, 2026, immediately following the Parks and Recreation Committee which starts at 6:00 pm.

FINANCE COMMITTEE MEETING
Tuesday, January 27, 2026
5:30 pm

MINUTES

Committee: Chairperson Ms. Dugan, Ms. Burckley, Mr. Ewald, and Ms. Vogel
Staff: Mr. Krack, Ms. Getzfreed, Ms. Koza-Lubinsky, Ms. Donato, and Ms. Niemczuk

I. Call to Order at 5:30 pm

II. Public Comment on Non-Agenda Items

There was no public comment.

III. Committee Member Updates/Discussions

There were no updates or discussion.

IV. New Business

A. Motion to recommend Borough Council approve the 2025 Pre-Paid dated 11/1/2025 - 11/30/2025 in the amount of \$854,371.52.

Mr. Ewald made a Motion to recommend Borough Council approve the Pre-Paid as presented. Second by Ms. Burckley. Motion passed 4-0.

B. Motion to recommend Borough Council approve the 2025 Pre-Paid dated 12/1/2025 - 12/31/2025 in the amount of \$2,342,451.86.

Mr. Ewald made a Motion to recommend Borough Council approve the Pre-Paid as presented. Second by Ms. Burckley. Motion passed 4-0.

C. Motion to recommend Borough Council approve the 2025 Pre-Paid Credit Card Statement dated 11/1/2025 - 11/30/2025 in the amount of \$63,752.76.

Mr. Ewald made a Motion to recommend Borough Council approve the Pre-Paid as presented. Second by Ms. Burckley. Motion passed 4-0.

D. Motion to recommend Borough Council approve the 2025 Pre-Paid Credit Card Statement dated 12/1/2025 - 12/31/2025 in the amount of \$38,351.51.

Ms. Burckley made a Motion to recommend Borough Council approve the Pre-Paid as presented. Second by Mr. Ewald. Motion passed 4-0.

- E. Motion to recommend Borough Council approve the 2025 Pre-Paid ACH dated 11/30/2025 in the amount of \$1,719,111.70.

Ms. Burckley made a Motion to recommend Borough Council approve the Pre-Paid as presented. Second by Mr. Ewald. Motion passed 4-0.

- F. Motion to recommend Borough Council approve the 2025 Pre-Paid ACH dated 12/31/2025 in the amount of \$68,593.93.

Ms. Burckley made a Motion to recommend Borough Council approve the Pre-Paid as presented. Second by Mr. Ewald. Motion passed 4-0.

- G. Motion to recommend Borough Council approve the Staff recommendation authorizing the Finance Director to make the necessary end of year adjustments and to provide a listing of those adjustments to the Finance Committee and the Borough's Auditor.

Mr. Ewald made a Motion to recommend Borough Council approve the recommendation as presented. Second by Ms. Burckley. Motion passed 4-0.

V. Public Comment

There was no public comment.

VI. Adjournment at 5:45 pm by Ms. Burckley.

Next Meeting Date: Tuesday, February 24, 2026 at 6:00 pm